

**FW**  
**r1.38**

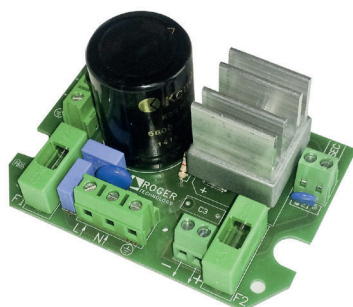

IS122 Rev.07 14/07/2022

# B70/1B - B70/PW

## centrale di comando per porta basculante

Istruzioni originali

**ROGER**  
BRUSHLESS



- IT - Istruzioni ed avvertenze per l'installatore
- EN - Instructions and warnings for the installer
- DE - Anweisungen und Hinweise für den Installateur
- FR - Instructions et consignes pour l'installateur
- ES - Instrucciones y advertencias para el instalador
- PT - Instruções e advertências para o instalador

**ROGER**  
TECHNOLOGY



# INDICE • INDEX • INDEX • INDEXER • ÍNDICE • ÍNDICE • INDEX • INDEKS

## ITALIANO

1	Avvertenze generali	12
2	Descrizione prodotto	12
3	Caratteristiche tecniche prodotto	12
4	Descrizione dei collegamenti	13
4.1	Collegamenti elettrici	13
5	Tasti funzione e display	15
6	Accensione o messa in servizio	15
7	Modalità funzionamento display	16
8	Apprendimento della corsa	18
9	Menù parametri modalità semplificata (impostazione di fabbrica)	19
10	Menù parametri modalità estesa	21
11	Comandi e accessori	27
12	Segnalazione degli ingressi di sicurezza e dei comandi (modalità TEST)	29
13	Segnalazione allarmi e anomalie	30
14	Sblocco meccanico	31
15	Modalità di recupero posizione	31
16	Collaudo	31
17	Manutenzione	31
18	Smaltimento	31
19	Informazioni aggiuntive e contatti	32
20	Dichiarazione di Conformità	32

## DEUTSCH

1	Allgemeine Sicherheitshinweise	54
2	Produktbeschreibung	54
3	Technische Daten des Produkts	54
4	Beschreibung der Anschlüsse	55
4.1	Elektrische Anschlüsse	55
5	Funktionstasten und Display	57
6	Einschalten oder Inbetriebnahme	57
7	Funktion Display	58
8	Einlernen des Torlaufs	60
9	Menü Parameter vereinfachter Modus (Werkseinstellung)	61
10	Menü Parameter erweiterter Modus	63
11	Befehle und Zubehör	69
12	Meldung der Sicherheitseingänge und der Befehle (TEST-Modus)	71
13	Meldung von Alarmen und Störungen	72
14	Mechanische Entriegelung	73
15	Modus zur Korrektur der Position	73
16	Abnahmeprüfung	73
17	Wartungsarbeiten	73
18	Entsorgung	73
19	Zusätzliche Informationen und Kontakte	74
20	Konformitätserklärung	74

## ENGLISH

1	General safety precautions	33
2	Product description	33
3	Technical characteristics of product	33
4	Description of connections	34
4.1	Electrical connections	34
5	Function buttons and display	36
6	Switching on or commissioning	36
7	Display function modes	37
8	Travel acquisition	39
9	Parameter menu in simplified mode (default setting)	40
10	Parameter menu in extended mode	42
11	Commands and Accessories	48
12	Safety input and command status (TEST mode)	50
13	Alarms and faults	51
14	Mechanical release	52
15	Position recovery mode	52
16	Initial testing	52
17	Maintenance	52
18	Disposal	52
19	Additional information and contact details	53
20	Declaration of Conformity	53

## FRANÇAIS

1	Consignes générales de sécurité	75
2	Description produit	75
3	Caractéristiques techniques produit	75
4	Description des raccordements	76
4.1	Raccordements électriques	76
5	Touches fonction et écran	78
6	Allumage ou mise en service	78
7	Modalités fonctionnement écran	79
8	Apprentissage de la course	81
9	Menu paramètres modalité simplifiée (param. d'usine)	82
10	Menu paramètres modalité étendue	84
11	Commandes et accessoires	90
12	Signalisation des entrées de sécurité et des commandes (modalités TEST)	92
13	Signalisations alarmes et anomalies	93
14	Déblocage mécanique	94
15	Modalités de récupération position	94
16	Test	94
17	Entretien	94
18	Élimination	94
19	Informations complémentaires et contacts	95
20	Déclaration de conformité	95

## ESPAÑOL

1	Advertencias generales	96
2	Descripción del producto	96
3	Características técnicas del producto	96
4	Descripción de las conexiones	97
4.1	Conexiones eléctricas	97
5	Teclas de función y pantalla	99
6	Encendido o puesta en servicio	99
7	Modo de funcionamiento de la pantalla	100
8	Aprendizaje del recorrido	102
9	Menú de parámetros del modo simplificado (configuración de fábrica)	103
10	Menú de parámetros del modo extendido	105
11	Comandos y accesorios	111
12	Señalización de las entradas de seguridad y de los comandos (Modo TEST)	113
13	Señalización de alarmas y anomalías	114
14	Desbloqueo mecánico	115
15	Modo de recuperación de la posición	115
16	Ensayo	115
17	Mantenimiento	115
18	Eliminación	115
19	Información adicional y contactos	116
20	Declaración de Conformidad	116

## PORTUGUÊS

1	Advertências gerais	117
2	Descrição do produto	117
3	Caraterísticas técnicas do produto	117
4	Descrição das ligações	118
4.1	Ligações elétricas	118
5	Teclas de função e display	120
6	Ignição ou comissionamento	120
7	Modalidade de funcionamento do display	121
8	Aprendizagem do curso	123
9	Menu de parâmetros da modalidade simplificada (programação de fábrica)	124
10	Menu de parâmetros da modalidade estendida	126
11	Comandos e acessórios	132
12	Sinalização das entradas de segurança e dos comandos (modalidade TEST)	134
13	Sinalização de alarmes e anomalias	135
14	Desbloqueio mecânico	136
15	Modalidade de recuperação de posição	136
16	Teste	136
17	Manutenção	136
18	Descarte	136
19	Informações adicionais e contatos	137
20	Declaração de conformidade	137

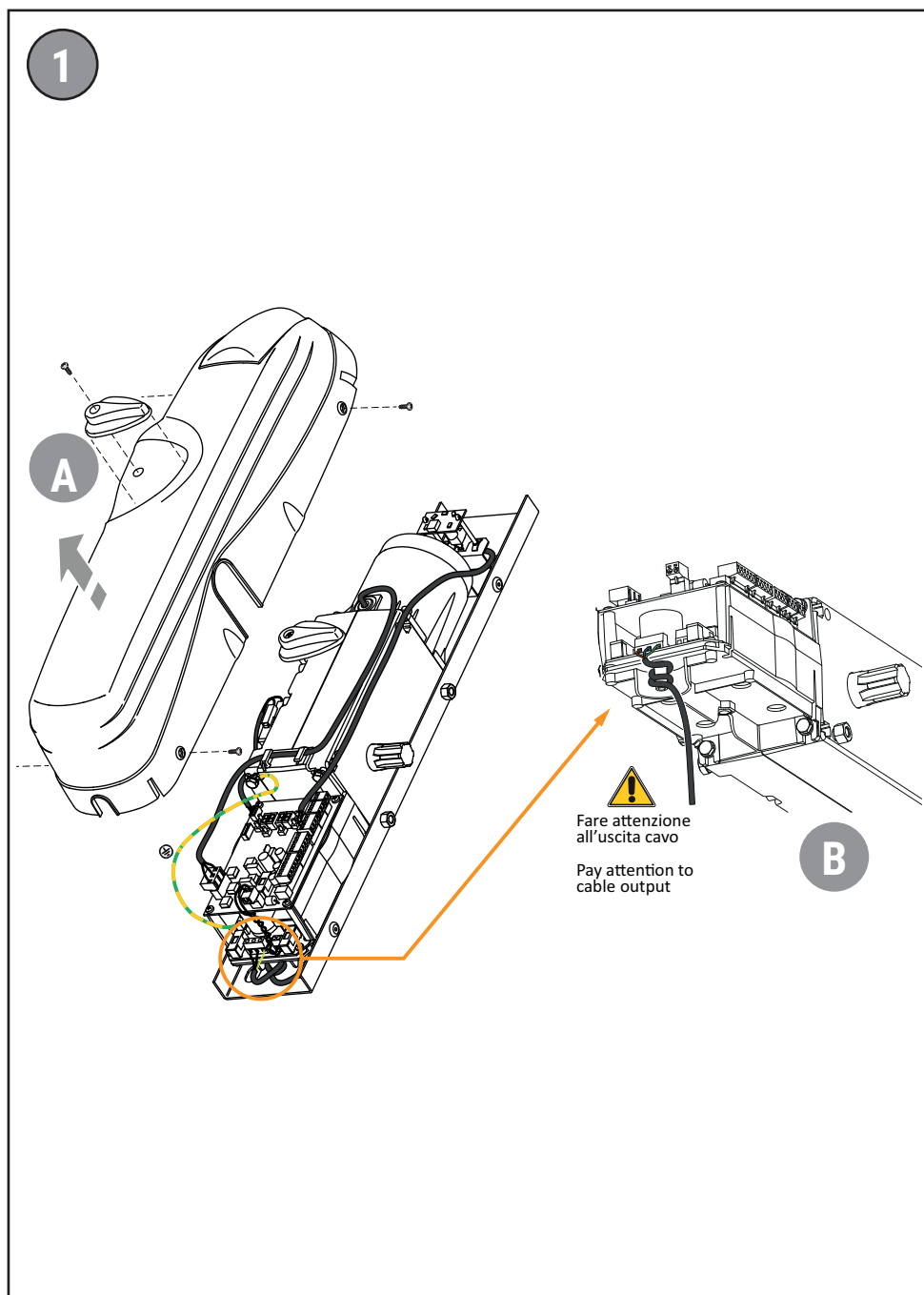

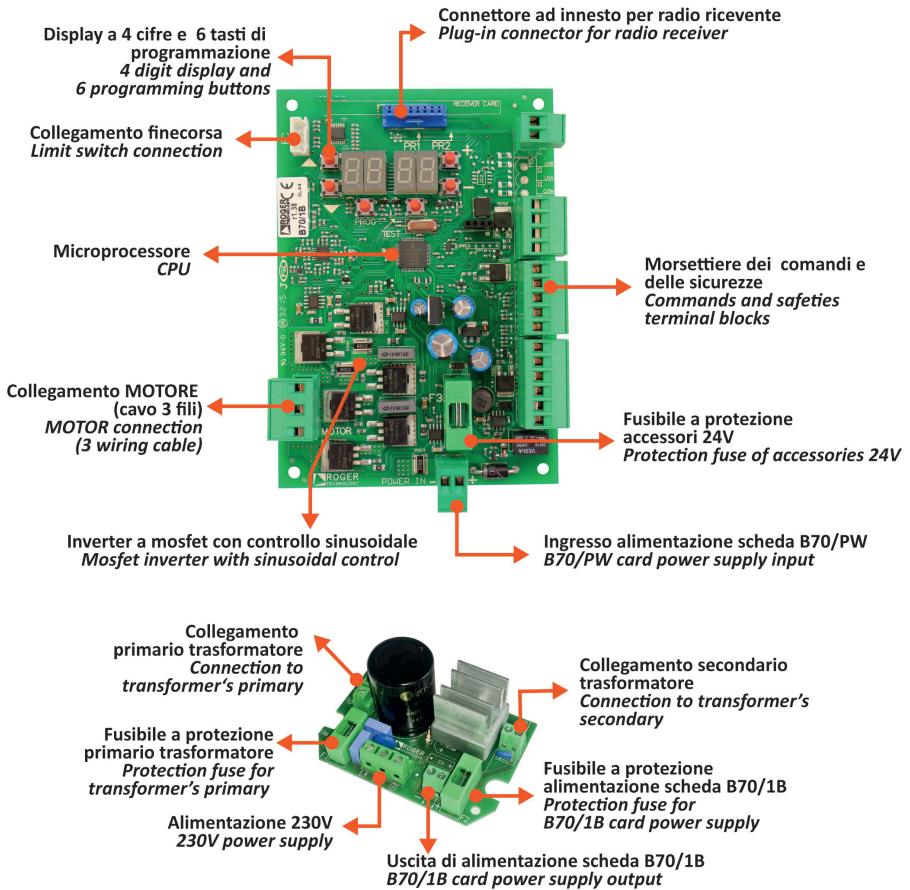

3

RICEVITORE RADIO  
RADIO RECEIVER

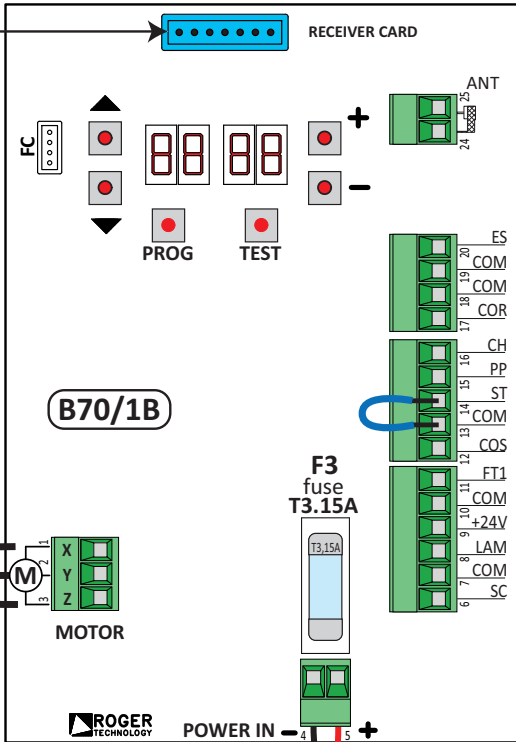

MOTORE  
MOTOR

TRASFORMATORE  
TRANSFORMER

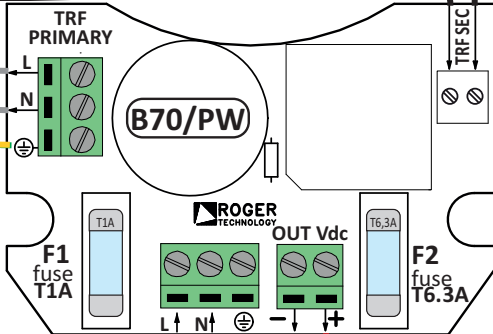

230Vac



4

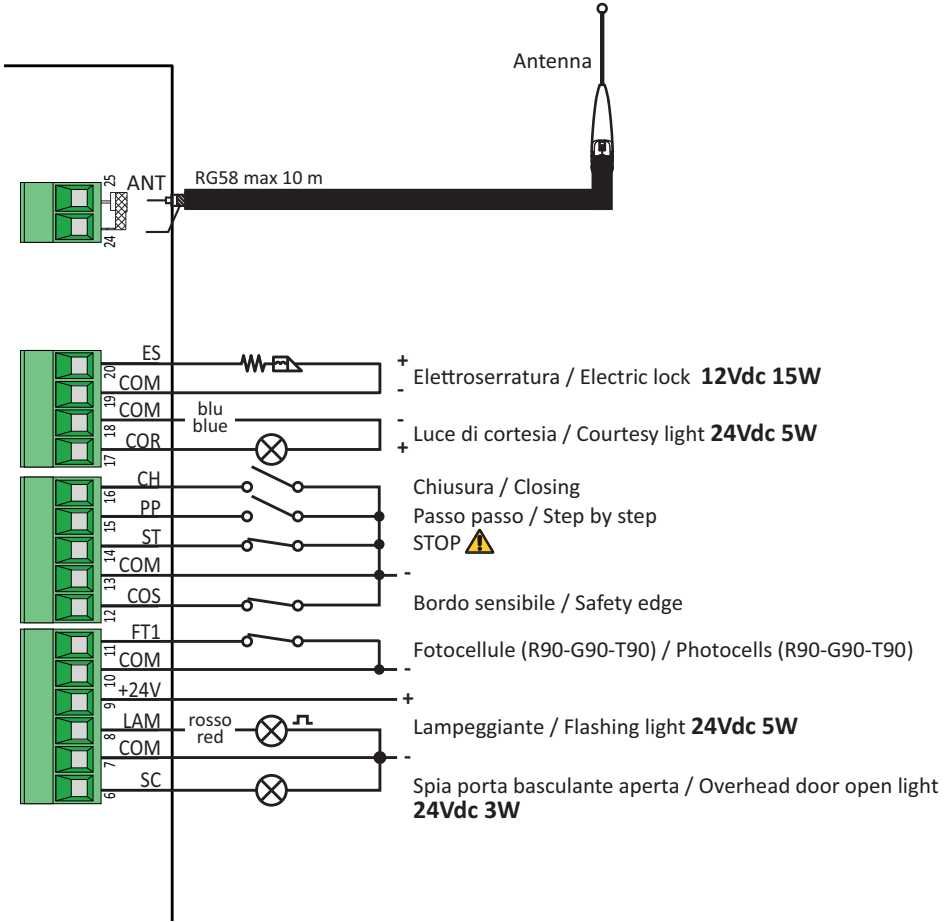



**COLLEGAMENTO CON 1 COPPIA FOTOCELLE SINCROZZATE (MODALITÀ NORMALE, SOLO COPPIA MASTER)**  
**CONNECTION WITH 1 SYNCHRONISED PHOTOCCELL PAIR (NORMAL MODE, MASTER PAIR ONLY)**

ROSSO = libero da jumper  
 RED = jumper free

5

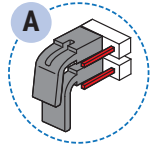
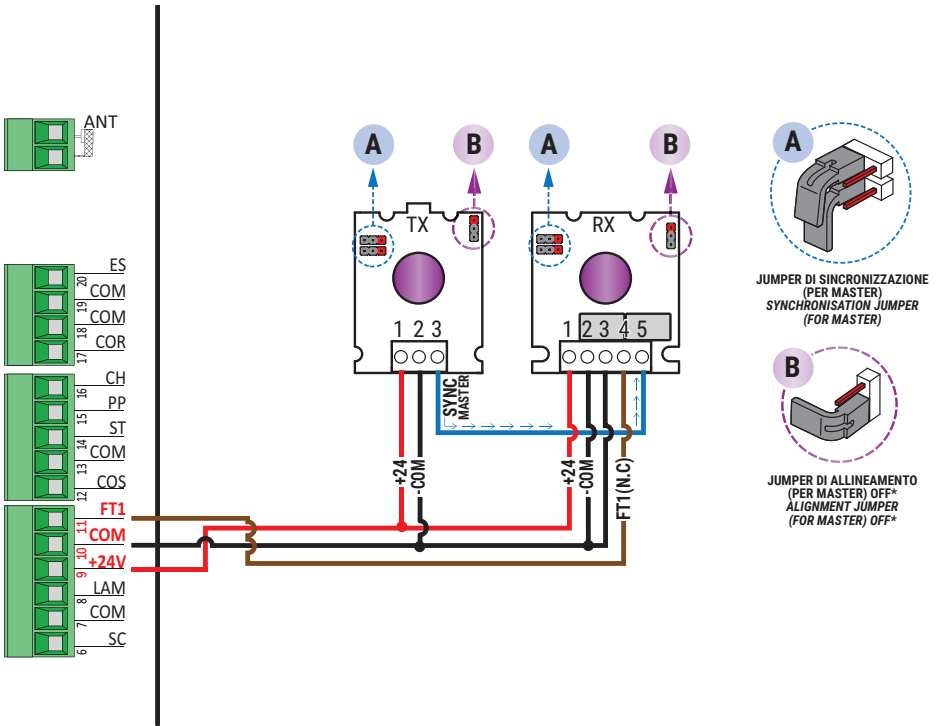

**JUMPER DI SINCROZZAZIONE (PER MASTER)**  
**SYNCHRONISATION JUMPER (FOR MASTER)**

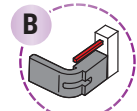

**JUMPER DI ALLINEAMENTO (PER MASTER) OFF\***  
**ALIGNMENT JUMPER (FOR MASTER) OFF\***

\* Per eseguire la modalità in di allineamento ottico  
 (NOTA: consultare le istruzioni delle fotocelle):  
 \* To perform optical alignment mode  
 (NOTE: refer to photocell instructions):

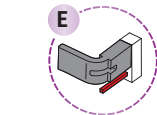
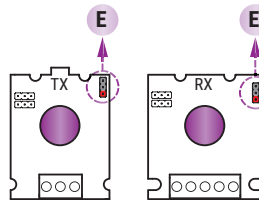

**JUMPER DI ALLINEAMENTO ON\***  
**ALIGNMENT JUMPER ON\***



**ATTENZIONE!** Modificare la posizione dei jumper di sincronizzazione o di allineamento solamente quando le fotocelle sono **NON ALIMENTATE!** La configurazione scelta con i jumper viene memorizzata dalle fotocelle solamente all'accensione delle fotocelle.

Scollegare la morsetteria della centrale che fornisce alimentazione alle fotocelle, oppure togliere completamente la tensione al controller digitale (scollegando, se presenti, anche le batterie di backup) e verificare nella fotocella TX / RX che il LED rosso di alimentazione sia spento; procedere soltanto ora all'impostazione della configurazione dei jumper.

**ATTENTION!** Please ensure that the photocell jumpers are only changed with the power to the control panel switched off, including the disconnection of any battery backup. Remove the terminal of the photocell inputs or completely remove the voltage from the digital controller (check that the digital controller is not powered by backup batteries) and check that the TX / RX photocell red power LED is off.

**SI RACCOMANDA L'USO DI** fotocelle Serie **F4ES - F4S** / **RECOMMENDED USE for** Series **F4ES - F4S** photocells

## TEST FOTOCELLULE · PHOTOCELLS TEST (AB 02)

### COLLEGAMENTO CON 1 COPPIA FOTOCELLULE SINCRONIZZATE (MODALITÀ NORMALE, SOLO COPPIA MASTER) CONNECTION WITH 1 SYNCHRONISED PHOTOCCELL PAIR (NORMAL MODE, MASTER PAIR ONLY)

ROSSO = libero da jumper  
RED = jumper free

5

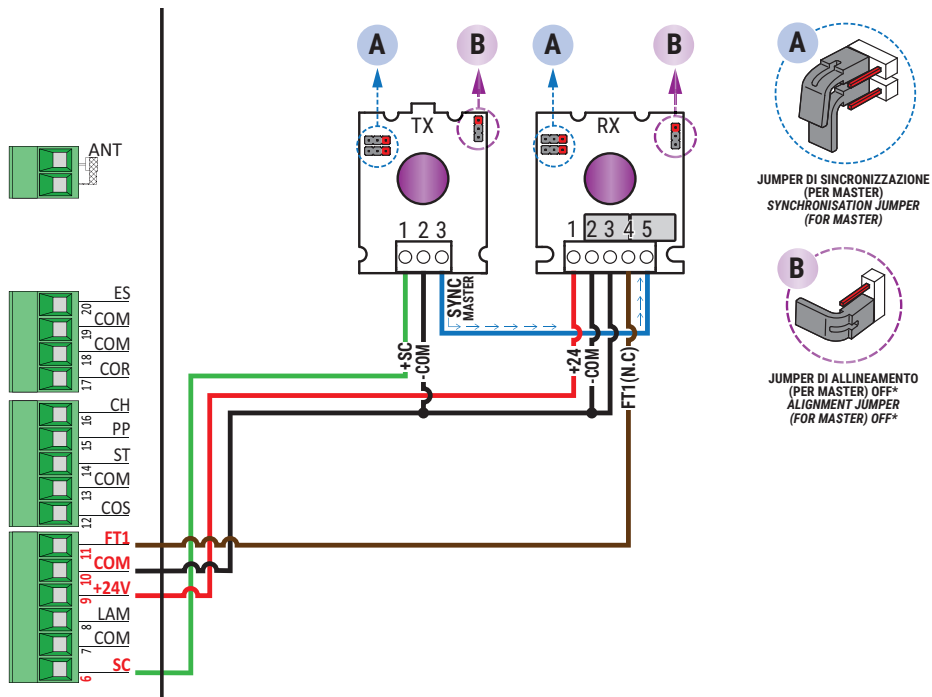

**A**  
JUMPER DI SINCRONIZZAZIONE  
(PER MASTER)  
SYNCHRONISATION JUMPER  
(FOR MASTER)

**B**  
JUMPER DI ALLINEAMENTO  
(PER MASTER) OFF\*  
ALIGNMENT JUMPER  
(FOR MASTER) OFF\*

\* Per eseguire la modalità in di allineamento ottico  
(NOTA: consultare le istruzioni delle fotocellule):  
\* To perform optical alignment mode  
(NOTE: refer to photocell instructions):

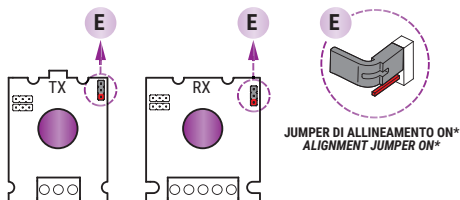

**E**  
JUMPER DI ALLINEAMENTO ON\*  
ALIGNMENT JUMPER ON\*



**ATTENZIONE!** Modificare la posizione dei jumper di sincronizzazione o di allineamento solamente quando le fotocellule sono **NON ALIMENTATE!** La configurazione scelta con i jumper viene memorizzata dalle fotocellule solamente all'accensione delle fotocellule.



Scollegare la morsetteria della centrale che fornisce alimentazione alle fotocellule, oppure togliere completamente la tensione al controller digitale (scollegando, se presenti, anche le batterie di backup) e verificare nella fotocellula TX / RX che il LED rosso di alimentazione sia spento; procedere soltanto ora all'impostazione della configurazione dei jumper.

**ATTENTION!** Please ensure that the photocell jumpers are only changed with the power to the control panel switched off, including the disconnection of any battery backup. Remove the terminal of the photocell inputs or completely remove the voltage from the digital controller (check that the digital controller is not powered by backup batteries) and check that the TX / RX photocell red power LED is off.

**SI RACCOMANDA L' USO DI** fotocellule Serie **F4ES - F4S** / **RECOMMENDED USE** for Series **F4ES - F4S** photocells

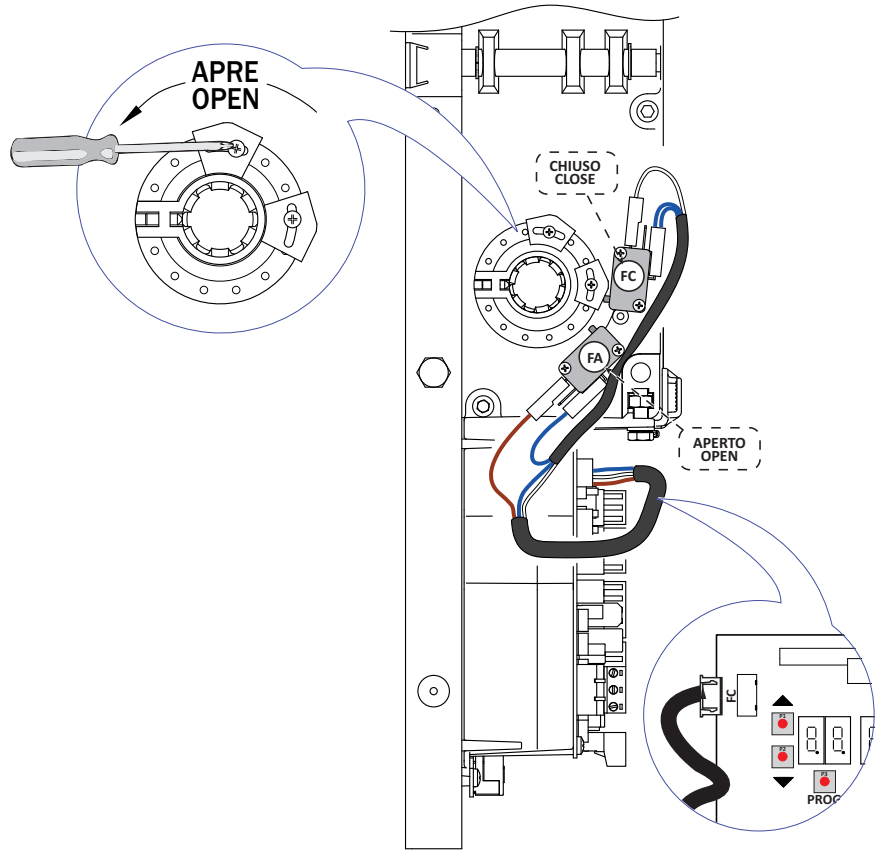
6

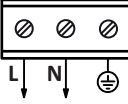
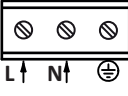

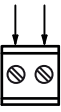
B70/PW	
	DESCRIPTION
<b>TRF PRIMARY</b> 	N.B.: Ready wired in factory by ROGER TECHNOLOGY.
	<b>L</b> Transformer primary winding 230 Vac.
	<b>N</b> Transformer primary winding 230 Vac.
	<b>L</b> (Line) Mains power input, 230 Vac 50 Hz.
	<b>N</b> (Neutral) Mains power input, 230 Vac 50 Hz.
	 Ground connection to motor (see <b>figure 3</b> ).
<b>V DC OUT</b> 	0 Vdc (-) and 28 Vdc (+) power output for <b>B70/1B</b> motor control unit. Connect the OUT (-) terminal of the <b>B70/PW</b> power board to the POWER IN (-) terminal of the <b>B70/1B</b> control unit with the black wire. Connect the OUT (+) terminal of the <b>B70/PW</b> power board to the POWER IN (+) terminal of the <b>B70/1B</b> control unit with the red wire. Check that the two wires (red and black) are twisted together (see <b>figure 3</b> ). <b>N.B.:</b> Ready wired in factory by ROGER TECHNOLOGY.
	<b>TRF SEC</b> 

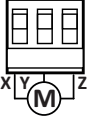
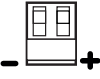
B70/1B	
	DESCRIPTION
<b>X-Y-Z</b> 	Connection to ROGER brushless motor. <b>N.B.:</b> Ready wired in factory by ROGER TECHNOLOGY.
<b>POWER IN</b> 	Power input from B70/PW board. <b>N.B.:</b> Ready wired in factory by ROGER TECHNOLOGY.

## 5 Function buttons and display

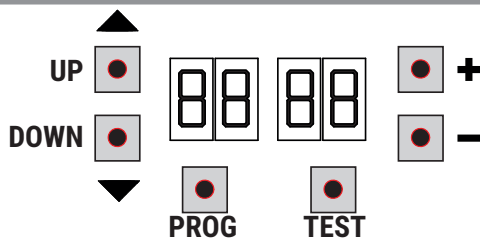

BUTTON	DESCRIPTION
UP ▲	Next parameter
DOWN ▼	Previous parameter
+	Increase value of parameter by 1
-	Decrease value of parameter by 1
PROG	Programme travel
TEST	Activate TEST mode

- Press the UP ▲ and/or DOWN ▼ buttons to view the parameter you intend to modify.
- Use the + and - buttons to modify the value of the parameter. The value starts to flash.
- Press and hold the + or - button to scroll quickly through values, to modify the parameter more quickly.
- To save the new value, wait a few seconds or move onto another parameter with the UP ▲ or DOWN ▼ button. The display flashes rapidly to indicate that the new value has been saved.
- Parameters can only be modified while the motor is not running. Parameters can be viewed at any time.

## 6 Switching on or commissioning

Power the control unit.

The firmware version of the control unit is displayed briefly.

Version installed r1.38.



Immediately afterwards, the displays enters the commands and safety device status mode. See chapter 7.

### **N.B.: simplified mode is set by default.**

If advanced mode is activated, the display returns automatically to the simplified parameter menu mode after 30 minutes with no user input or the next time the control unit is switched on or reset.

To switch from simplified mode to advanced mode, see chapter 7.

## 7 Display function modes

### • **Parameter display mode**

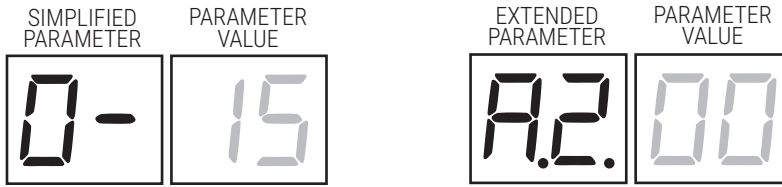

See chapters 9 and 10 for detailed descriptions of the parameters in SIMPLIFIED and EXTENDED mode.

To switch from simplified mode to extended mode.

- press and hold the UP ▲ and DOWN ▼ buttons simultaneously for 4 seconds;
- the first parameter in extended mode is shown on the display.

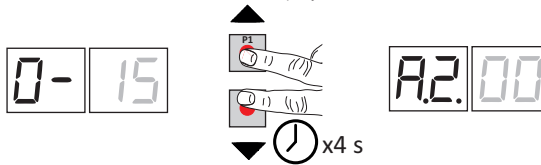

Repeat the procedure to return to simplified mode.

### • **Command and safety device status display mode**

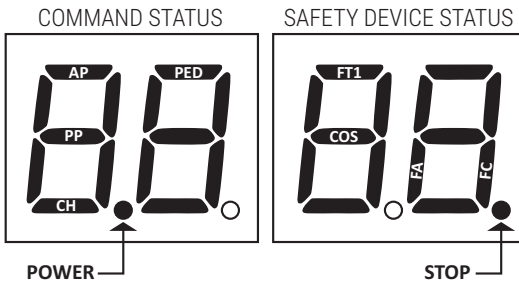

#### **COMMAND STATUS:**

The command status indicators on the display (segments AP = open, PP = step mode, CH = close, PED = pedestrian) are normally off. They illuminate when a command is received (e.g.: when a step mode command is received, the segment PP illuminates).

The command signals AP and PED are not received from the terminal board and are generated by the remote control (see parameters 76 and 77).

#### **SAFETY DEVICE STATUS:**

The safety device status indicators on the display (segments FT1 = photocells, COS = sensing edge, FA = door open limit switch, FC = door closed limit switch) are normally on. If an indicator is off, the relative device is in alarm state or is not connected.

The indicator is flashing, the relative device has been disabled with a specific parameter.

## • TEST mode

The TEST mode is used to test activation of the commands and safety devices with visual confirmation.

To activate the mode, press the TEST button with the automatic door system at rest. If the door is moving, pressing TEST stops the door. Pressing the button again enables TEST mode.

The flashing light and the door open indicator lamp illuminate for one second.

The command signal status is shown on the left hand side of the display for 5 seconds, ONLY when the respective command signal is active (AP, CH, PP, PE). For example, if the door open command is activated, the letters AP appear on the display.

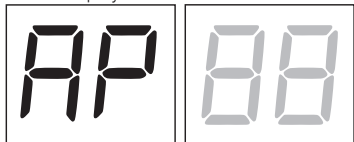

The status of the safety devices/inputs is shown on the right hand side of the display. The number of the terminal relative to the safety device in alarm state flashes.

When the door is completely open or completely closed, *FR* or *FC* is shown on the display to indicate that the overhead door has reached the door open limit switch *FR* or door closed limit switch *FC*.

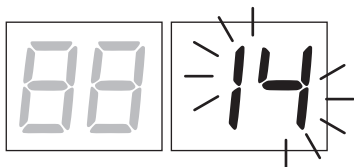

00	No safety device in alarm state, and no limit switch activated
14	STOP
12	Sensing edge
11	Photocell
FE	Both limit switches
FR	Door open limit switch
FC	Door closed limit switch

N.B.: If more than one safety device is in alarm state, once the problem relative to the first device is resolved, the alarm for the next device is displayed. Any further alarm states are also displayed with the same logic.

Press the TEST button again to exit test mode.

After 10 seconds with no user input, the display returns to command and safety device state display mode.

## • Standby mode

This mode is activated after 30 minutes with no user input. The POWER LED flashes slowly.

Press UP ▲, DOWN ▼, + or - to reactivate the control unit.

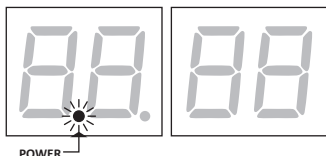

Standby mode restores the SIMPLIFIED parameter display mode.

## 8 Travel acquisition

For the system to function correctly, the door travel must be acquired by the control.

Before starting:

1. Move the door into the fully closed position. The control unit determines the open and close travel values electronically. If any difference found between the two travel values, the acquisition procedure fails.
2. Press **TEST** (see TEST mode in chapter 7) and check the command signal and safety device states. If any safety devices are not installed, jumper the relative contact or disable the device from the relative parameter (50, 51, 73).
3. Check that the limit switches are set correctly. Check the door closed limit switch in particular.

### ACQUISITION PROCEDURE:

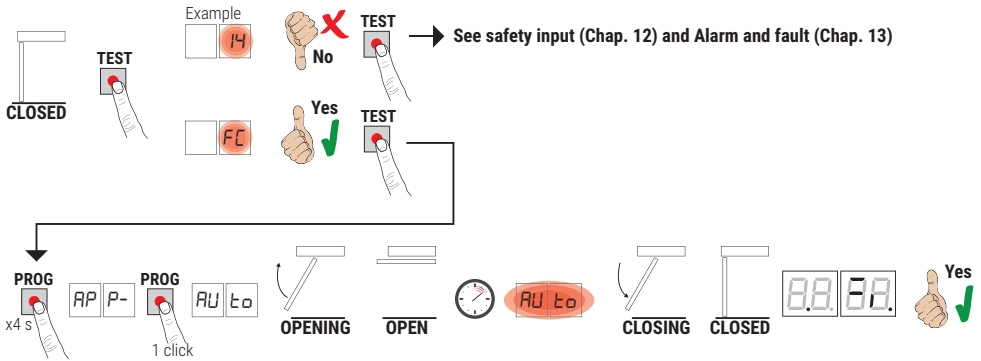

- Press and hold **PROG** for 4 seconds. **RP P-** is shown on the display.
- Press **PROG** again. **RU t0** is shown on the display.
- The door starts opening at low speed.
- The door stops briefly when it reaches the door open limit switch. **RU t0** flashes on the display.
- The door closes until it reaches the door closed stop.

If the acquisition procedure is completed successfully, the display enters the command and safety device state display mode.

If the following error messages are shown on the display, repeat the acquisition procedure:

- **RP PE**: acquisition error
- **RP PL**: travel length error
- **RP PC**: door closed limit switch error. Check that the door closed limit switch is set correctly (see chapter 11).



## 9 Parameter menu in simplified mode (default setting)

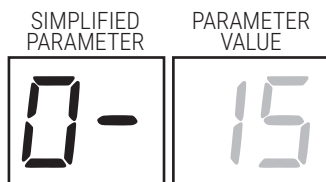

The control unit is configured in simplified display mode by default, with standard values suitable for the majority of installations.

See chapter 10 for the extended parameter display mode.

<b>0- 15</b>	<b>Setting obstacle detection sensitivity</b>
01- 10	Low motor torque: 01 = minimum obstacle impact force ... 10 = maximum obstacle impact force <b>N.B.:</b> only use these settings if the medium motor torque values are not suitable for the installation.
11- 19	Medium motor torque. <b>Recommended setting for adjusting force settings correctly.</b> 11 = minimum obstacle impact force ... 19 = maximum obstacle impact force.
20	Maximum motor torque. May only be used if the door is equipped with a sensing edge.
<b>1- 00</b>	<b>Automatic closure after pause time (from door completely open)</b>
00	Disabled.
01- 15	Number of door closure attempts after photocell is triggered. Once the number of attempts set is reached, the door remains open.
99	The door tries to close indefinitely.
<b>2- 60</b>	<b>Setting automatic closing time</b>
	The timer starts from the door open state and continues for the set time. Once the set time is reached, the door closes automatically. The timer count restarts if a photocell is triggered.
00- 90	Pause time settable from 00 to 90 s.
92- 99	Pause time settable from 2 to 9 min.
<b>3- 00</b>	<b>Automatic door closing after mains power outage</b>
00	Disabled. The door does not close automatically when mains power is restored.
01	Enabled. If the overhead door is NOT completely open, when mains power is restored, the door closes after a 5 second warning signalled with the flashing light (independently of the value set with the parameter <i>R5</i> in extended mode). The door closes in "position recovery" mode (see chapter 15).
<b>4- 05</b>	<b>Setting motor stop distance</b>
01- 05	01= faster deceleration/shorter stop distance ... 05= slower deceleration/longer stop distance.
<b>5- 00</b>	<b>Pre-flashing</b>
00	Disabled. The flashing light is activated during opening and closing manoeuvres.
01- 10	Flashing warning signal for 1 to 10 seconds prior to every manoeuvre.
99	5 second flashing warning signal prior to closing manoeuvre.

<b>6-00</b>	<b>Selecting step mode control function</b>
00	Open-stop-close-stop-open-stop-close...
01	Condominium function: the door opens and closes after the set automatic closing time. The automatic closing timer restarts if a new step mode command is received. Step mode commands are ignored while the door is opening. This allows the door to open completely and prevents the door from closing when not required.
02	Condominium function: the door opens and closes after the set automatic closing time. The automatic closing timer does NOT restart if a new step mode command is received. Step mode commands are ignored while the door is opening. This allows the door to open completely and prevents the door from closing when not required.
03	Open-close-open-close.
04	Open-close-stop-open.
<b>7-00</b>	<b>Configuring flashing light frequency</b>
00	The frequency is set electronically from the flashing light unit.
01	Slow flash.
02	Light flashes slowly when door opens, rapidly when door closes.
<b>8-08</b>	<b>Setting opening start acceleration</b>
01-10	01= the door accelerates rapidly at start of manoeuvre ... 10= the door accelerates slowly and progressively at start of manoeuvre.
<b>9-05</b>	<b>Setting opening speed</b>
01-05	01= minimum speed ... 05= maximum speed.
<b>A-04</b>	<b>Setting opening deceleration</b>
01-05	01= the door decelerates near the limit switch ... 05= the door decelerates long before the limit switch.
<b>b-08</b>	<b>Setting closure start acceleration</b>
01-10	01= the door accelerates rapidly at start of manoeuvre ... 10= the door accelerates slowly and progressively at start of manoeuvre.
<b>C-05</b>	<b>Setting closure speed</b>
01-05	01= minimum speed ... 05= maximum speed.
<b>d-04</b>	<b>Setting closure deceleration</b>
01-05	01= the door decelerates near the limit switch ... 05= the door decelerates long before the limit switch.

## 10 Parameter menu in extended mode

EXTENDED  
PARAMETER



PARAMETER  
VALUE



To switch from simplified mode to extended mode.

- press and hold the UP ▲ and DOWN ▼ buttons simultaneously for 4 seconds;
- the first parameter in extended mode is shown on the display.

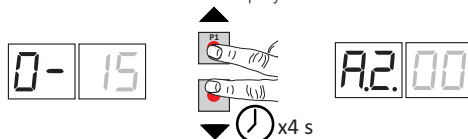

Repeat the procedure to return to simplified mode.

**WARNING!** The sequence of parameters in simplified mode is not the same as the sequence in extended mode - always refer to the instruction manual.

<b>A2 00</b>	<b>Automatic closure after pause time (from door completely open)</b>
00	Disabled.
0 1- 15	Number of door closure attempts after photocell is triggered. Once the number of attempts set is reached, the door remains open.
99	The door tries to close indefinitely.
<b>A3 00</b>	<b>Automatic door closing after mains power outage</b>
00	Disabled. The door does not close automatically when mains power is restored.
0 1	Enabled. If the overhead door is NOT completely open, when mains power is restored, the door closes after a 5 second warning signalled with the flashing light (independently of the value set with the parameter A5 in extended mode). The door closes in "position recovery" mode (see chapter 15).
<b>A4 00</b>	<b>Selecting step mode control function (PP)</b>
00	Open-stop-close-stop-open-stop-close...
0 1	Condominium function: the gate opens and closes after the set automatic closing time. The automatic closing timer restarts if a new step mode command is received. Step mode commands are ignored while the gate is opening. This allows the gate to open completely and prevents the gate from closing when not required. If automatic closing is disabled (A2 00), the condominium function automatically attempts a closing manoeuvre A2 0 1.
0 2	Condominium function: the gate opens and closes after the set automatic closing time. The automatic closing timer does NOT restart if a new step mode command is received. Step mode commands are ignored while the gate is opening. This allows the gate to open completely and prevents the gate from closing when not required. If automatic closing is disabled (A2 00), the condominium function automatically attempts a closing manoeuvre A2 0 1.
0 3	Open-close-open-close.
0 4	Open-close-stop-open.
<b>A5 00</b>	<b>Pre-flashing</b>
00	Disabled. The flashing light is activated during opening and closing manoeuvres.
0 1- 10	Flashing warning signal for 1 to 10 seconds prior to every manoeuvre.
99	5 second flashing warning signal prior to closing manoeuvre.

<b>A6 00</b>	<b>Condominium function for partial open command (from remote control)</b>
00	Disabled. The door opens partially in step mode: open-stop-close-stop-open...
01	Enabled. Partial commands are ignored during door opening.
<b>A8 00</b>	<b>Overhead door open indicator / photocell test function</b>
00	The indicator is off when the door is closed, and steadily lit during manoeuvres and when the door is open.
01	The indicator flashes slowly during opening manoeuvres, and is lit steadily when the door is completely open. It flashes quickly during closing manoeuvres. If the door is stopped in an intermediate position, the lamp extinguishes twice every 15 seconds.
02	Set 02 if the output <b>SC</b> is used for the photocell test. See fig. 6.
<b>11 04</b>	<b>Setting deceleration during opening</b>
<b>12 04</b>	<b>Setting deceleration during closing</b>
01-05	01= the door decelerates near the limit switch ... 05= the door decelerates long before the limit switch.
<b>13 10</b>	<b>Setting door closed position</b> The value set must ensure that the door is closed correctly after the limit switch is activated. <b>Warning!</b> Excessively high values impede obstacle detection within the final 5 cm of door travel. Excessively low values cause the door to reverse (open) when it reaches the door closed stop.
01-20	Motor revolutions.
<b>14 00</b>	<b>Setting pressure against door closed stop</b> <b>N.B.:</b> as the door approaches the door closed stop, once the limit switch is activated, the control unit reduces the torque applied by the motor to prevent the structure of the overhead door from bending or straining. <b>Warning!</b> This parameter must be set in relation to the type of door installed and the mounting used for the gear motor.
00-09	00= minimum force...09= maximum force.
<b>15 50</b>	<b>Partial opening adjustment (%)</b> <b>N.B.:</b> This parameter is set to 50% (half of total door travel) by default. The partial opening command may only be sent from the remote control (see parameters 76/ 77).
10-85	From 10% to 85% of total door travel.
<b>21 60</b>	<b>Setting automatic closing time</b> The timer starts from the door open state and continues for the set time. Once the set time is reached, the door closes automatically. The timer count restarts if a photocell is triggered.
00-90	Pause time settable from 00 to 90 s.
92-99	Pause time settable from 2 to 9 min.
<b>27 03</b>	<b>Setting reverse time after activation of sensing edge or obstacle detection (crush prevention)</b> This sets the reverse manoeuvre time after activation of the sensing edge or the obstacle detection system.
00-30	From 0 to 30 s.
<b>29 01</b>	<b>Enable electric lock</b>
00	Disabled.
01	Enabled. The electric lock is activated for a period of 3 seconds 0.5 seconds before the start of the manoeuvre. When the door is close to the door closed stop, the control unit assists re-engagement of the electric lock.

<b>30 05</b>	<b>Setting motor torque</b>
	Increasing or decreasing the value of the parameter increases or decreases motor torque and, as a result, adjusts obstacle detection sensitivity. We recommend using a value of 0 / ONLY for particularly lightweight installations not exposed to severe weather conditions (strong winds or very cold temperatures).
0 1-09	01= -35%; 02= -25%; 03= -16%; 04= -8% (reduced motor torque = increased sensitivity). 05= default motor torque setting. 06= +8%; 07= +16%; 08= +25%; 09= +35% (increased motor torque = reduced sensitivity).

<b>31 15</b>	<b>Setting obstacle detection sensitivity</b>
	If the reaction time to obstacle impact force is too long, reduce the value of the parameter. If the impact force exerted on obstacles is too high, reduce the value of parameter 30.
0 1- 10	Low motor torque: 01 = minimum obstacle impact force ... 10 = maximum obstacle impact force <b>N.B.:</b> only use these settings if the medium motor torque values are not suitable for the installation.
1 1- 19	Medium motor torque. <b>Recommended setting for adjusting force settings correctly.</b> 11 = minimum obstacle impact force ... 19 = maximum obstacle impact force.
20	Maximum motor torque. May only be used if the door is equipped with a sensing edge.

<b>33 08</b>	<b>Setting opening start acceleration</b>
--------------	---

<b>34 08</b>	<b>Setting closure start acceleration</b>
--------------	---

0 1- 10	01= the door accelerates rapidly at start of manoeuvre ... 10= the door accelerates slowly and progressively at start of manoeuvre.
---------	---

<b>40 05</b>	<b>Setting opening speed (%)</b>
--------------	----------------------------------

<b>41 05</b>	<b>Setting closure speed (%)</b>
--------------	----------------------------------

0 1-05	01= 60% minimum speed, 02= 70%, 03= 80%, 04=90%, 05= 100% maximum speed.
--------	--

<b>49 00</b>	<b>Setting number of automatic closure attempts after activation of sensing edge or obstacle detection (crush protection)</b>
--------------	---

00	No automatic closure attempts.
0 1-03	From 1 to 3 automatic closure attempts. We recommend setting a value equal to or lower than the value set for parameter A2. Automatic closure is only performed if the door is completely open.

<b>50 00</b>	<b>Setting photocell mode during door opening (FT1)</b>
--------------	---

00	DISABLED. Photocell is not active or not installed.
0 1	STOP. The door stops and remains stationary until the next command is received.
02	IMMEDIATE REVERSE. The door reverses immediately if the photocell is activated during door opening.
03	TEMPORARY STOP. The door stops as long as the photocell is obstructed. The door resumed opening when the photocell is cleared.
04	DELAYED REVERSE. The door stops if the photocell is obstructed. The door closes when the photocell is cleared.

<b>51 02</b>	<b>Setting photocell mode during door closing (FT1)</b>
--------------	---

00	DISABLED. Photocell is not active or not installed.
0 1	STOP. The door stops and remains stationary until the next command is received.
02	IMMEDIATE REVERSE. The door reverses immediately if the photocell is activated during door closure.
03	TEMPORARY STOP. The door stops as long as the photocell is obstructed. The door resumed closing when the photocell is cleared.
04	DELAYED REVERSE. The door stops if the photocell is obstructed. The door opens when the photocell is cleared.

52 01	Photocell (FT1) mode with door closed
00	If the photocell is obstructed, the door cannot open.
01	The door opens when an open command is received, even if the photocell is obstructed.
02	The photocell sends the door open command when obstructed.

56 00	Enable close command 6 s after activation of photocell (FT1)
00	Disabled.
01	Enabled. When the photocell barrier is crossed, a close command is sent 6 seconds later.

65 05	Setting motor stop distance
01-05	01= faster deceleration/shorter stop distance ... 05= slower deceleration/longer stop distance.

73 01	Configuring sensing edge
00	Sensing edge NOT INSTALLED.
01	NC contact (normally closed). The door reverses only when closing.
02	Contact with 8k2 resistor. The door reverses only when closing.
03	NC contact (normally closed). The door always reverses.
04	Contact with 8k2 resistor. The door always reverses.

76 00	Configuring radio channel 1 (PR1)
-------	-----------------------------------

77 03	Configuring radio channel 2 (PR2)
-------	-----------------------------------

00	STEP MODE.
01	PARTIAL OPENING
02	OPENING
03	CLOSING.
04	STOP.
05	Courtesy light. The output COR is managed from the remote control. The light remains lit as long as the remote control is active. The parameter 79 is ignored.
06	Courtesy light in step mode (PP). The output COR is managed from the remote control. The remote control turns the courtesy light on and off. The parameter 79 is ignored.
07	STEP MODE with confirmation for safety. <sup>(1)</sup>
08	PARTIAL OPENING with confirmation for safety. <sup>(1)</sup>
09	OPENING with confirmation for safety. <sup>(1)</sup>
10	CLOSURE with confirmation for safety. <sup>(1)</sup>

<sup>(1)</sup> To prevent door manoeuvres caused by accidentally pressing a remote control button, confirmation is required to enable the command. Example: parameters 76 07 and 77 01 set:

- Pressing the CHA button on the remote control selects the step mode function, which must be confirmed within 2 seconds by pressing CHB on the remote control. Press CHB to activate partial opening.

78 00	Configuring flashing light frequency
00	The frequency is set electronically from the flashing light unit.
01	Slow flash.
02	Light flashes slowly when door opens, rapidly when door closes.

79 60	Selecting courtesy light mode
-------	-------------------------------

00	Disabled.
01	PULSE. The courtesy light illuminates briefly at the start of each manoeuvre.
02	ACTIVE. The light remains lit for the entire duration of the manoeuvre.
03-90	From 3 to 90 s. The light remains lit for the time period set after the manoeuvre is completed.
92-99	From 2 to 9 minutes. The light remains lit for the time period set after the manoeuvre is completed.

<b>81 00</b>	<b>Enable safeguarded door closure/opening</b> Enabling this parameter ensures that the door is not left open due to an incorrect and/or accidental command. This function is <b>NOT</b> enabled if: <ul style="list-style-type: none"> <li>• the door receives a STOP command;</li> <li>• the sensing edge is activated;</li> <li>• the door is completely open (due to parameters <i>B2</i> and 49).</li> <li>• the acquired position is lost (perform position recovery, see chapter 15).</li> </ul>
00	Disabled. The parameter <i>B2</i> is not displayed.
01	Enabled. <sup>(1)</sup> After a period of time set with parameter <i>B2</i> , the control unit signals a 5 second warning with the flashing light, regardless of the parameter <i>A5</i> , and then closes the door.
02	Enabled. <sup>(1)</sup> If the door is closed as a result of a step mode command, after a period of time set with parameter <i>B2</i> , the control unit signals a 5 second warning with the flashing light (regardless of the parameter <i>A5</i> ), and then the door closes. If the door is stopped by the obstacle detection system during a closure manoeuvre, the door closes after a period of time set with parameter <i>B2</i> . If the door is stopped by the obstacle detection system during an opening manoeuvre, the door closes after a period of time set with parameter <i>B2</i> .

<sup>(1)</sup> If the control unit detects a collision occurring in the same position 5 consecutive times, the function is disabled and the motor is set to safety mode. The door will then complete the manoeuvre only when a command is received.  
If the control unit detects more than 20 collisions during opening and/or closure within an 8 minute period, the function is disabled and the motor is set to safety mode. The door will then complete the manoeuvre only when a command is received.

<b>82 03</b>	<b>Setting safeguarded closure/opening activation time</b>
02-90	Wait time settable from 2 to 90 s.
92-99	Wait time settable from 2 to 9 min.

<b>90 00</b>	<b>Restoring factory default values</b> <b>NOTE</b> This procedure is only possible if NO data protection password is set.	
	<p><b>Warning!</b> Restoring default settings cancels all settings made previously except for parameter <i>A1</i>: after restore, check that all parameters are suitable for the installation.</p> <ul style="list-style-type: none"> <li>• Press and hold the PLUS + and MINUS - button until the unit switches on.</li> </ul>	<ul style="list-style-type: none"> <li>• The display flashes after 4 s <math>\overline{E5}</math>.</li> <li>• The default factory settings have now been restored.</li> </ul>
	<p><b>Note:</b> it is possible to reset the parameters in a second way: when the control unit is switched on, before the firmware version appears on the display, press and hold down the ▲ (UP ARROW) and ▼ (DOWN ARROW) buttons for 4s.</p>	

<b>Identification number</b>	
The identification number consists of the values of the parameters from <i>n0</i> to <i>n6</i> . <b>N.B.:</b> The values shown in the table are indicative only.	
<i>n0 01</i>	<b>HW version.</b>
<i>n1 23</i>	<b>Year of manufacture.</b>
<i>n2 45</i>	<b>Week of manufacture.</b>
<i>n3 67</i>	Example: 01 23 45 67 89 01 23
<i>n4 89</i>	
<i>n5 01</i>	
<i>n6 23</i>	
	<b>Serial number.</b>
	<b>FW version.</b>

<b>View manoeuvre counter</b>	
The number consists of the values of the parameters from $a0$ to $a1$ multiplied by 100. <b>N.B.:</b> The values shown in the table are indicative only.	
$a001$	<b>Manoeuvres performed.</b> Example: $0123 \times 100 = 12300$ manoeuvres.
$a123$	
<b>View manoeuvre hour counter</b>	
The number consists of the values of the parameters from $h0$ to $h1$ . <b>N.B.:</b> The values shown in the table are indicative only.	
$h001$	<b>Manoeuvre hours.</b> Example: $0123 = 123$ hours.
$h123$	
<b>View control unit days on counter</b>	
The number consists of the values of the parameters from $d0$ to $d1$ . <b>N.B.:</b> The values shown in the table are indicative only.	
$d001$	<b>Days with unit switched on.</b> Example: $0123 = 123$ days.
$d123$	
<b>Password</b>	
Setting a password prevents unauthorised persons from accessing the settings. With password protection active ( $CP=01$ ), parameters may be viewed in simplified and advanced modes, but the values CANNOT be modified. <u>Only a single password is used to control access to the door automation system.</u> <b>WARNING:</b> Contact the Technical Support Service if you lose your password.	
$P100$ $P200$ $P300$ $P400$	<p><b>Password activation procedure:</b></p> <ul style="list-style-type: none"> <li>• Enter the desired values for parameters <math>P1</math>, <math>P2</math>, <math>P3</math> and <math>P4</math>.</li> <li>• Use the UP ▲ and/or DOWN ▼ buttons to view the parameter <math>CP</math>.</li> <li>• Press and hold the + and - buttons for 4 seconds.</li> <li>• The display flashes to confirm that the password has been saved.</li> <li>• Switch the control unit off and on again. Check that password protection is activated (<math>CP=01</math>).</li> </ul> <p><b>Temporary unlock procedure:</b></p> <ul style="list-style-type: none"> <li>• Enter the password.</li> <li>• Check that <math>CP=00</math>.</li> </ul> <p><b>Password cancellation procedure:</b></p> <ul style="list-style-type: none"> <li>• Enter the password (<math>CP=00</math>).</li> <li>• Save the values <math>P1</math>, <math>P2</math>, <math>P3</math>, <math>P4 = 00</math></li> <li>• Use the UP ▲ and/or DOWN ▼ buttons to view the parameter <math>CP</math>.</li> <li>• Press and hold the + and - buttons for 4 seconds.</li> <li>• The display flashes to confirm that the password has been cancelled (the values <math>P100</math>, <math>P200</math>, <math>P300</math> and <math>P400</math> indicate that no password is set).</li> <li>• Switch the control unit off and on again.</li> </ul>
<b>Changing password</b>	
$CP00$	
$00$	Protection deactivated.
$01$	Protection activated.











## 11 Commands and Accessories

 If not installed, safety devices with NC contacts must be jumpered at the COM terminals, or disabled by modifying the parameters **50**, **51** and **73** in the extended menu.

KEY:

N.A. (Normally Open) .  
N.C. (Normally Closed).

CONTACT	DESCRIPTION
<b>6(SC)</b>  <b>7(COM)</b>	Connection for door open indicator lamp (24 Vdc - 3 W).
<b>6(SC)</b> <b>10(COM)</b>	Photocell test connection. The power feed for the photocell transmitters (TX) may be connected to this. Set the parameter <b>AB02</b> to enable the test function. Each time a command is received, the control unit switches the photocells off and on to check that the contact changes state correctly. <b>WARNING!</b> If contact <b>6-SC</b> is used for the photocell test function, a overhead door open indicator lamp cannot be connected.
<b>8(LAM)</b>  <b>7(COM)</b>	Connection for flashing light (24 Vdc max. 25 W duty cycle 50%). The settings for the pre-manoeuvre flashing warning signal may be selected with parameter <b>A5</b> , while the flashing mode is set with parameter <b>7B</b> .
<b>9(+24V)</b> <b>10(COM)</b>	Power feed for external devices, max. 7 W (300 mA).
<b>11(FT1)</b>  <b>10(COM)</b>	Input (NC) for connecting photocells (fig. 5 and 6). The photocells are configured by default with the following settings: <ul style="list-style-type: none"> <li><b>5000</b>. Photocell triggers only during door closure. Photocell is ignored during door aperture.</li> <li><b>5102</b>. Movement is reversed if the photocell is triggered during door closure.</li> <li><b>5201</b>. The door opens when an open command is received if the photocell is obstructed.</li> </ul> If the photocells are not installed, jumper the terminals <b>10(COM) - 11(FT1)</b> or set the parameters <b>5000</b> and <b>5100</b> . <b>WARNING!</b> Use <b>R90/F4ES</b> , <b>G90/F4ES</b> or <b>T90/F4S</b> series photocells.
<b>12(COS)</b>  <b>13(COM)</b>	Input (NC or 8 kOhm) for connecting sensing edge. The sensing edge is configured by default with the following settings. <ul style="list-style-type: none"> <li><b>7301</b>. Movement is reversed if the sensing edge (NC contact) is activated during door closure.</li> </ul> If the sensing edge is not installed, jumper the terminals <b>12(COS) - 13(COM)</b> or set the parameter <b>7300</b> .
<b>14(ST)</b>  <b>13(COM)</b>	STOP command input (N.C.). The current manoeuvre is arrested if the safety contact opens. <b>N.B.:</b> the controller is supplied with this contact already jumpered by ROGER TECHNOLOGY.
<b>15(PP)</b>  <b>13(COM)</b>	Step mode command input (NO).
<b>16(CH)</b>  <b>13(COM)</b>	Close command input (NO).
<b>17(COR)</b> <b>18(COM)</b>	Output (24 Vdc 5W) for connecting H70/COR courtesy light. <b>N.B.:</b> Ready wired in factory by ROGER TECHNOLOGY.
<b>20(ES)</b> <b>19(COM)</b>	Output (12 Vdc 15W) for powering electric lock.
<b>24</b>  <b>25(ANT)</b>	Antenna connector for slot-in radio receiver board. Use RG58 if an external antenna is used; maximum recommended length: 10 m. <b>N.B.:</b> do not make joints in cable.
<b>RECEIVER CARD</b>	Connector for slot-in radio receiver board. The <b>B70/1B</b> control unit has two radio remote control functions by default: <ul style="list-style-type: none"> <li>PR1 - step mode command (modifiable with parameter <b>75</b>).</li> <li>PR2 - close command (modifiable with parameter <b>77</b>).</li> </ul>

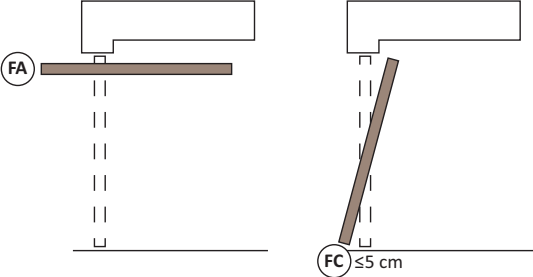
CONTACT	DESCRIPTION
<b>FC</b>	<p>Connector (NC contacts) for connecting mechanical limit switches (see figure 7).</p> <p><b>N.B.:</b> Ready wired in factory by ROGER TECHNOLOGY.</p> <p>Adjust the door open limit switch so that the overhead door stops after activation of the limit switch and before the door open stop.</p> <p>Adjust the door closed limit switch so that it is activated when the door reaches a distance no greater than 5 cm from the door closed stop.</p> <p>Once activated, the limit switch must not be released until the manoeuvre is completed.</p> <p>If the limit switch is adjusted correctly, when the limit switch is activated, the door continues as far as the stop and then stops.</p> <p>If the limit switch is not adjusted correctly, the door reverses direction.</p> <p><b>WARNING!</b> The pressure exerted against the stop is determined by the parameter <math>\mu_4</math>. This value must be set in relation to the type of overhead door structure, to prevent problems such as bending or warping.</p>  <p><b>N.B.:</b> After each adjustment to the positions of the limit switches, the travel acquisition procedure must be repeated (chapter 8).</p>

## 12 Safety input and command status (TEST mode)

With no currently active commands, press the TEST button and check the following:

DISPLAY	POSSIBLE CAUSE	ACTION BY SOFTWARE	PHYSICAL CORRECTIVE ACTION
BB 14	The safety STOP contact is open.	-	Install a STOP button (NC) or jumper the ST contact with the COM contact.
BB 12	Sensing edge not connected or incorrectly connected.	Set the parameter 73 00 if not used or to disable	Jumper contact COS with contact COM, if not used or to disable
BB 11	Photocell FT1 not connected or incorrectly connected.	Set the parameter 50 00 and 51 00 if not used or to disable	Jumper contact FT1 with contact COM, if not used or to disable. Check connection referring to relative connection diagram (figures 5-6).
BB FE	Both limit switches in open contact state or not connected.	-	Check connection of limit switches.
BB FA	Door is at door open limit switch.	-	-
	Door open limit switch absent or not connected.	-	Check connection of limit switches.
BB FC	Door is at door closed limit switch.	-	-
	Door closed limit switch absent or not connected.	-	Check connection of limit switches.
PP 00	Faulty contact or incorrect button connection.	-	Check contact and connections to button.
CH 00	Faulty contact or incorrect button connection.	-	Check contact and connections to button.
AP 00	Possible transmission fault or the radio transmission is activated.	-	Make sure that no radio buttons are activated wrongfully; remove and reconnect radio board or replace with new board.
PE 00		-	

**N.B.:** Press **TEST** button to exit from the **TEST** Mode.

We recommend troubleshooting safety device and input status errors with "corrective action by software" only.

## 13 Alarms and faults

PROBLEM	ALARM	POSSIBLE CAUSE	ACTION
The door does not open or close.	POWER LED off	No power.	Check power cable.
	POWER LED off	Fuse F1, F2 or F3 blown.	Replace fuse. Always disconnect from mains power before removing fuses.
	<i>DF SE</i>	Input mains power voltage fault. Control initialisation failed.	Disconnect from mains power, wait 10 seconds then reconnect to the mains and switch on. We recommend replacing the control unit if the problem persists.
	<i>Pr DE</i>	Overcurrent detected in inverter.	Press the <b>TEST</b> button twice or perform 3 command requests in succession.
	<i>DATA</i>	Travel data acquisition error.	Check that open and closed limit switches are positioned correctly. Press TEST and check if any safety devices are in alarm state. Repeat acquisition procedure.
	<i>Not FE</i>	Motor not connected.	Check the motor cable.
	Example: <i>15 EE</i> <i>21 EE</i>	Configuration parameter error.	Set configuration value correctly and save.
Acquisition procedure does not complete correctly.	<i>AP PE</i>	TEST button pressed accidentally.	Repeat acquisition procedure.
		Safety devices in alarm state.	Check connections of safety devices.
		Excessive voltage drop.	Repeat acquisition procedure. Check mains voltage
	<i>AP PL</i>	Travel length error.	Move the door into the fully closed position and repeat the procedure.
	<i>AP PC</i>	Limit switch error.	Check that door closed limit switch is in correct position.
Remote control has limited range and does not work while automated door is moving.		The radio transmission is impeded by metal structures and reinforced concrete walls.	Install the antenna outside.
Remote control has limited range and does not work while automated door is moving.		Flat batteries.	Replace the transmitter batteries.
The flashing light is not working.		Bulb / LED blown or flashing light wires disconnected.	Check LED circuit and/or connector wires.
Door open indicator lamp does not work.		Bulb blown or wires disconnected.	Check the bulb and/or wires.
Door does not perform desired manoeuvre.		Motor leads crossed.	Swap two wires on terminal X-Y-Z.

**N.B.:** Press the TEST button to temporarily cancel the alarm.

The next time a command is received, the alarm reappears on the display if the problem has not been resolved.

## 14 Mechanical release

In the event of a fault or mains power loss, the door may be manually released (see release instructions in user manual for BR41 automated door system).

When the release system is restored to the normal operating position, if the door is not completely open or completely closed the next time a command is received, the control initiates a position recovery procedure (see chapter 15).

Activating one of the two limit switches immediately reacquires the position.

## 15 Position recovery mode

After a mains power outage or after mechanically releasing the door, if the door is not completely open or completely closed the next time a command is received, the control initiates a position recovery procedure:

- The door starts a low speed manoeuvre.
- The flashing light flashes with a different duty cycle than normal (3 s on, 1.5 s off).
- The control unit recovers the installation data during this procedure. **Warning!** During this procedure, do not use any controls until one of the two limit switches is reached.
- Activating one of the two limit switches immediately reacquires the position.

## 16 Initial testing

- Turn on the power supply.
- Check that all connected controls are working correctly.
- Check travel and deceleration.
- Check that the impact force is correct.
- Check that the safety devices are activated correctly. When an obstacle is detected, keep away from limit switches or any obstacles which may increase the risk of crushing.
- Disconnect from mains then reconnect and switch on again. Check that the door is repositioned correctly both when opened and when closed (perform test from a position with the limit switches activated).
- Check the limit switch settings. During opening, the door must stop before it hits the door open stop. During closure, the limit switch must be activated when the door is close to the door closed stop (at a distance no greater than 5 cm), and remain activated until the end of the manoeuvre.
- Check that the door closes completely and does not push with excessive force against the door closed stop.
- Perform a number of complete door closure manoeuvres, from both the fully open position and an intermediate position.

## 17 Maintenance

Perform scheduled maintenance every 6 months.

Check cleanliness and function.

If the unit contains dirt, moisture, insects or other foreign matter, disconnect from mains power and clean the board and the housing.

Repeat the initial installation test procedure after cleaning.

If any corrosion is found on the printed circuit board, evaluate if it is necessary to replace the board itself.

## 18 Disposal



This product may only be uninstalled by qualified technical personnel, following suitable procedures for removing the product correctly and safely. This product consists of numerous different materials. Some of these materials may be recycled, while others must be disposed of correctly at the specific recycling or waste management facilities indicated by local legislation applicable for this category of product.

Do not dispose of this product as domestic refuse. Observe local legislation for differentiated refuse collection, or hand the product over to the vendor when purchasing an equivalent new product.

Local legislation may envisage severe fines for the incorrect disposal of this product.

**Warning!** Some parts of this product may contain substances that are harmful to the environment or dangerous and which may cause damage to the environment or health risks if disposed of incorrectly.

## 19 Additional information and contact details

ROGER TECHNOLOGY is the exclusive proprietor holder of all rights regarding this publication. ROGER TECHNOLOGY reserves the right to implement any modifications without prior notification. Copying, scanning or any alterations to this document are prohibited without express prior authorised from by ROGER TECHNOLOGY.

This instruction manual and the warnings for the installer are given in printed form and included in the box containing the product.

The digital version of this documentation (in PDF format) and all future revisions are available from the reserved area of our website **[www.rogertechnology.com/B2B](http://www.rogertechnology.com/B2B)**, in the section 'Self Service'.

### **ROGER TECHNOLOGY CUSTOMER SERVICE:**

business hours: Monday to Friday  
08:00 to 12:00 - 13:30 to 17:30  
Telephone no: +39 041 5937023  
E-mail: [support@rogertechnology.it](mailto:support@rogertechnology.it)  
Skype: support\_rogertechnology

To request support for any problems or for any other queries regarding the automation system, please compile the online form "REPAIRS" in the 'Self Service' area of our website **[www.rogertechnology.com/B2B](http://www.rogertechnology.com/B2B)**.

## 20 Declaration of Conformity

I the undersigned, as acting legal representative of the manufacturer

**Roger Technology - Via Botticelli 8, 31021 Bonisiolo di Mogliano V.to (TV)**

hereby DECLARE that the appliance described below:

Description: Control unit for overhead doors

Model: B70/1B

Is conformant with the legal requisites of the following directives:

- 2006/42/EC
- 2004/108/EC
- 2011/65/EC

and that all the standards and/or technical requirements indicated as follows have been applied:

EN 61000-6-3

EN 61000-6-2

Last two figures of year in which marking was applied **CE 15**.

Place: Mogliano V.to

Date: 21-07-2015

Signature





**ROGER TECHNOLOGY**  
Via S. Botticelli 8 • 31021 Bonisiolo di Mogliano Veneto (TV) • ITALIA  
PIVA 01612340263 • Tel. +39 041.5937023 • Fax. +39 041.5937024  
info@rogertechnology.com • [www.rogertechnology.com](http://www.rogertechnology.com)